

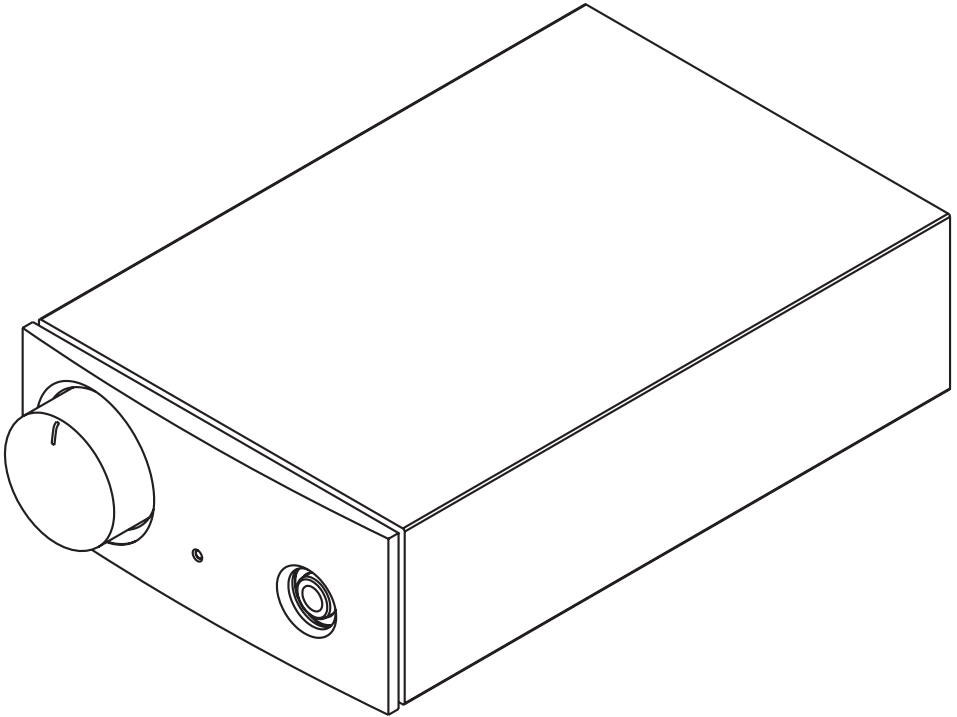

world class sound...



**NAPSC, i-SUPPLY, STAGELINE, HEADLINE
OWNERS MANUAL
ENGLISH**

SAFETY INSTRUCTIONS

In order to comply with current European safety regulations it is essential that the Naim loudspeaker connectors supplied with amplifiers and loudspeakers are used.

Do not under any circumstances allow anyone to modify your Naim equipment without first checking with the factory, your retailer, or your distributor. Unauthorised modifications will invalidate your guarantee.

Equipment must not be exposed to dripping or splashing and no objects filled with liquid, such as vases, should be placed on the equipment.

For your own safety do not under any circumstances open Naim equipment without first disconnecting it from the mains.

Warning: an apparatus with CLASS I construction shall be connected to a mains socket outlet with a protective earthing connection.

Where the mains plug or an appliance coupler is used as the disconnect device, the disconnect device shall remain readily operable. To disconnect the equipment from the mains remove the mains plug from the mains outlet.

The following label is attached to the NAPSC:



This equipment has been tested and found to comply with the relevant EMC and Safety Standards, and, where applicable, also complies with the limits for a class B digital device, pursuant to Part 15 of the FCC Rules.

These limits are designed to provide reasonable protection against harmful interference in a residential installation. This equipment generates, uses and

can radiate radio frequency and, if not installed and used in accordance with the instructions, may cause harmful interference to radio communications. However, there is no guarantee that interference will not occur in a particular installation. If this equipment does cause harmful interference to radio or television reception, which can be determined by turning off and on, the user is encouraged to try to correct the interference by one or more of the following measures:

- Reorient or relocate the receiving antenna.
- Increase the separation between the equipment and the receiver.
- Connect the equipment into an outlet on a circuit different from that to which the receiver is connected.
- Consult your Naim retailer or an experienced radio/TV technician for help.

Contents

Page	Section
1	1 Connections
	2 Mains Power
2	3 General Installation
4	4 Product Introduction
	5 NAPSC
5	6 i-Supply
	7 Headline
6	8 Stageline
8	9 Declaration of Conformity

Accessories

Naim Audio products are conceived with performance as the top priority. Careful installation will help ensure that their full potential is achieved. This manual covers the NAPSC and i-Supply power supplies, Headline headphone amplifier and Stageline phono amplifier. It begins with general installation notes and statutory safety warnings. Product specific information begins in Section 5.

1 Connections

It is important for both safety and performance that any standard cables supplied are not modified.

1.1 Analogue Audio Interconnect Cables

If options are available with your equipment and installation, DIN interconnect sockets should be used in preference to Phono sockets. One end of each Naim audio interconnect cable is marked with a band to establish its correct orientation. The band denotes the end that connects to the signal source. Naim Hi-Line interconnect cables will provide the best results.

Audio interconnect plugs and sockets should be kept clean and free from corrosion. The easiest way to clean them is to switch off the equipment, pull the plugs out of their sockets, and push them back in again. Contact cleaners and "enhancers" should not be used as the film they deposit may degrade the sound.

2 Mains Power

Where fused plugs are used 13 amp fuses should be fitted (i-Supply 3 amp). Fuses of a lower rating will fail after a period of use. Do not wire voltage dependent resistors or noise suppressors into mains plugs. They degrade the mains supply and the sound.

2.1 Mains Plug Wiring

In some territories a mains plug may need to be fitted to the supplied mains lead. As the colours of the wires in the mains lead may not correspond with the coloured markings identifying the terminals in the plug proceed as follows:

The wire coloured **GREEN-AND-YELLOW** must be connected to the terminal in the plug marked by the letter **E** or by the safety earth symbol or coloured **GREEN** or **GREEN** and **YELLOW**.

The wire coloured **BLUE** must be connected to the terminal in the plug marked with the letter **N** or coloured **BLACK**.

The wire coloured **BROWN** must be connected to the terminal in the plug marked with the letter **L** or coloured **RED**.

2.2 Equipment Fuses

Mains powered Naim Audio equipment is fitted with a mains fuse on the rear panel adjacent to the mains input socket (not i-Supply). Replace it if necessary only with the spare fuse supplied or with an identical fuse. Repeated failure of the fuse points to a fault that should be investigated by your retailer or Naim Audio.

2.3 Non-rewirable Mains Plugs

If a non-rewirable plug is cut from a mains lead (for whatever purpose) the plug **MUST** be disposed of in a way to render it totally useless. Considerable shock hazard exists if the cut-off plug is inserted into a mains outlet.

2.4 Mains Circuits and Cables

A hi-fi system usually shares a mains circuit with other household equipment some of which can cause distortion of the mains

Accessories

waveform. This distortion can in turn lead to mechanical hum from mains transformers. Some Naim transformers are large in size, making them relatively sensitive to such distortion, and it may be necessary to take account of transformer hum when siting your equipment.

Transformer hum is not transmitted through the speakers and has no effect on the performance of the system; however, a separate mains circuit may reduce it. Such a circuit (ideally with a 30 or 45 Amp rating) will also generally improve system performance. Advice on the installation of a separate mains circuit should be sought from a qualified electrician.

Use only the mains leads and plugs supplied or the Naim Power-Line mains cable.

3 General Installation

Naim equipment is designed to offer the finest performance possible avoiding compromise wherever practical. This can lead to circumstances that may be unfamiliar. The notes that follow contain advice specifically related to Naim equipment as well as more general warnings about the use of domestic audio products. Please read them carefully.

3.1 Siting The Equipment

In order to reduce the risk of hum audible from the loudspeakers, power supplies and power amplifiers should be located a reasonable distance away from other equipment. The maximum separation distance for connected equipment is that allowed by the standard interconnect lead.

Some Naim equipment is extremely heavy. Check the weight of the equipment prior to lifting and if necessary use more than one person so that it can be moved safely. Ensure that your equipment rack or table can easily support the weight and is stable.

3.2 Switching On

Source components and power supplies should be switched on before power amplifiers. Always switch amplifiers off and wait a minute before connecting or disconnecting any leads. Always use the power switch on the product rather than a mains outlet switch.

A “thump” may be heard from the loudspeakers as power amplifiers are switched on. This is normal, will not cause any loudspeaker damage and does not point to any fault or problem. A mild “pop” may also be heard shortly after equipment is switched off.

3.3 Running In

Naim equipment takes a considerable time to run in before it performs at its best. The duration varies, but under some conditions the sound may continue to improve for over a month. Better and more consistent performance will be achieved if the system is left switched on for long periods. It is worth remembering however that equipment left connected to the mains can be damaged by lightning.

3.4 Radio Interference

In some circumstances, depending on where you live and the earthing arrangements in your home, you may experience radio frequency interference. Controls on broadcasting in some territories allow very high levels of radio frequency radiation and both the choice and exact siting of equipment may be critical. Susceptibility to radio frequency interference is related to the wide internal bandwidth necessary for high sound quality. A radio frequency filter kit is available for some Naim equipment but sound quality will be progressively compromised as more elements of the kit are fitted. In situations of

Accessories

extreme radio interference Naim equipment may be unsuitable.

3.5 Lightning Precautions

Your Naim hi-fi system can be damaged by lightning and should be turned off and disconnected from the mains when there is risk of lightning. For complete protection all mains plugs and any aerial cables should be disconnected when not in use.

3.6 Problems?

Consumer protection varies from country to country. In most territories a retailer must be prepared to take back any equipment he has sold if it cannot be made to work satisfactorily. A problem may be due to a fault in the system or its installation so it is essential to make full use of your dealer's diagnostic skills. Please contact your local distributor, or Naim Audio directly, if any difficulties cannot be resolved.

Some Naim equipment is made in special versions for different territories and this makes it impracticable to arrange international guarantees. Please establish the local guarantee arrangements with your retailer. Contact Naim Audio directly for help and advice if necessary.

3.7 Service and Updates

It is essential that repairs and updates are only carried out by an authorised Naim retailer or at the Naim Audio factory. Many components are custom made, tested or matched and appropriate replacements are often unobtainable from other sources.

Direct contact to Naim for service or update information should be made initially through Customer Services:

Tel: **+44 (0)1722 426600**
Email: **info@naimaudio.com**

Please quote the product serial number in all correspondence.

Accessories

4 Product Introduction

This manual covers installation and operation of the NAPSC and i-Supply power supplies, Headline headphone amplifier and Stageline phono amplifier. All these products are fundamentally straightforward in use, however a little time spent reading will help ensure problem-free installation and use.

Equipment should be installed in its final location before connecting cables or switching on. Ensure that power amplifiers are switched off and the preamplifier volume is turned down before power supplies are switched on.

5 NAPSC

The NAPSC is a high quality power supply designed to power one Naim accessory product or the control circuits of a preamplifier. NAPSC is fitted with a captive lead terminated by a custom 2-pin plug.

5.1 NAPSC Rear Panel

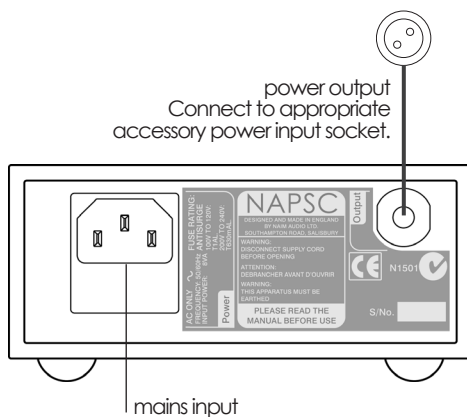

Accessories

6 i-Supply

The i-Supply is a simple power supply designed to power one Naim accessory product. i-Supply is fitted with a captive cable terminated by a 240° 5-pin DIN plug suitable for connection to a Stageline. An adaptor lead is required for use with a Headline.

6.1 i-Supply Connections

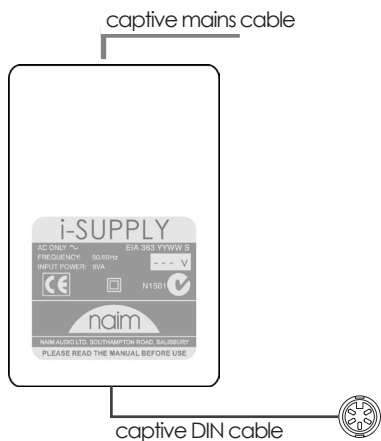

7 Headline

Headline is a high quality headphone amplifier compatible with the majority of high-quality headphones. It requires an external power supply to operate. The i-Supply, NAPSC, Flatcap 2, Hi-Cap and Supercap are compatible. Front panel features include a stereo headphone socket, a power indicator and a volume control.

7.1 Headline Rear Panel

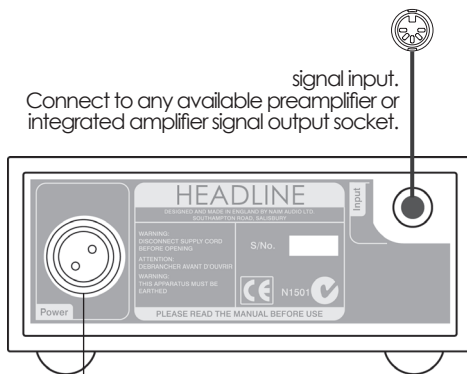

power supply input

Connect to:

i-Supply via captive lead and adaptor.

NAPSC via captive lead.

Flatcap via SLIC lead to Power Out Socket B.

Hi-Cap via SLIC lead to Socket 4.

Supercap via SLIC lead to Socket 2.

Note: To avoid ground loop problems, a Supercap used to power a Headline should not simultaneously power any other item.

Note: An RCA phono socket input version of the Headline is also available.

Accessories

8 Stageline

Stageline is a separate phono stage, factory configurable for either a moving magnet or moving coil cartridge. It requires an external power supply to operate. The i-Supply, Flatcap, Hi-Cap and Supercap are compatible. Stageline can also be powered via the power supply output on NAC 552, NAC 252,

NAC 282, NAC 202 and NAC 152 XS preamplifiers and SuperNait, Nait XS and Uniti integrated amplifiers.

8.1 Stageline Rear Panel

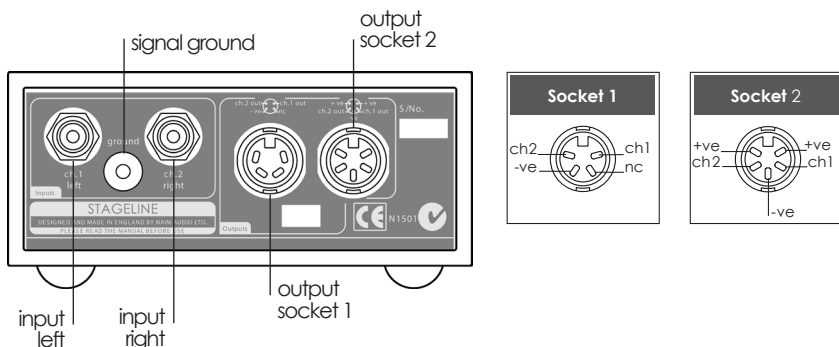

8.2 Stageline connected to NAIT 5i and i-Supply.

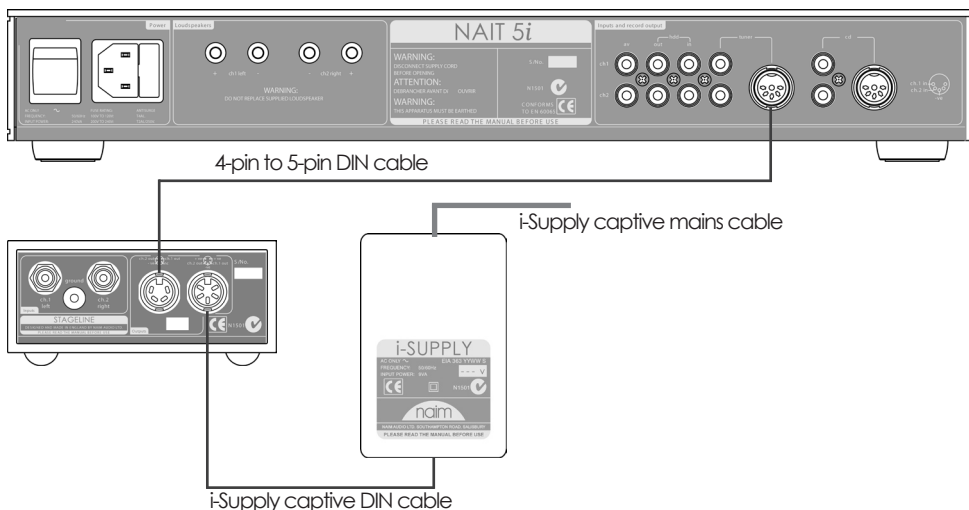

Accessories

8.3 Stageline connected to NAC 152 XS.

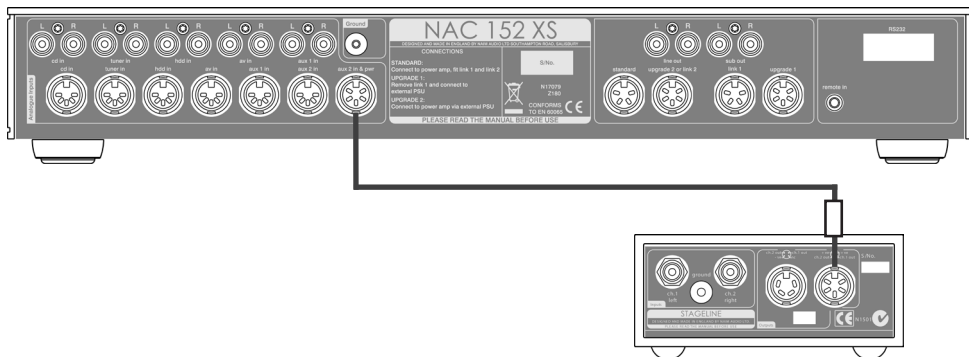

8.4 Stageline connected to NAC 152 XS and Flatcap XS.

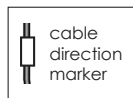
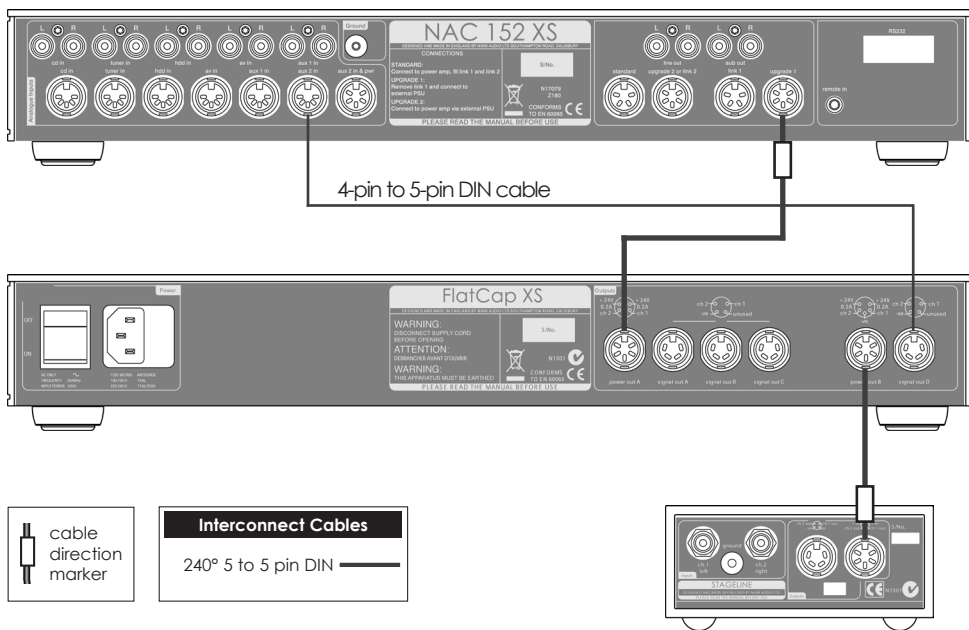

Interconnect Cables

240° 5 to 5 pin DIN

Accessories

9 Declaration of Conformity

Manufacturer:	Naim Audio Limited, Southampton Road, Salisbury, England, SP1 2LN
Product:	NAPSC, i-Supply, Headline, Stageline
Safety:	EN 60065 - Audio, Video and similar electronic apparatus.
EMC Emissions:	EN 55013 - Sound and television broadcast receivers and associated equipment - Radio disturbance characteristics - Limits and methods of measurements.
EMC Immunity:	EN 55020 - Sound and television receivers and associated equipment - Immunity Characteristics - Limits and methods of measurement.
In accordance with European Directives:	2006/95/EC - Safety 2004/108/EC - EMC



Naim Audio Limited, Southampton Road, Salisbury, England SP1 2LN
Tel: +44 (0)1722 426600 Fax: +44 (0)871 230 1012 W: www.naimaudio.com
E: info@naimaudio.com Part No. 12-001-0047 Iss. 2